

# LCP ANTIRUST System

Reduce consumption and increase protection of your rust preventative



TUBE MILLS | ROLL FORMERS



ENSURE COMPLETE  
COVERAGE AND PRECISE  
APPLICATION OF RUST  
PREVENTATIVE FOR  
YOUR TUBE!

- ▶ 60% reduction of consumption
- ▶ Eliminate product claims
- ▶ No overspray
- ▶ Guaranteed 100% tube coverage
- ▶ Eliminate harmful oils from the air and shop floor

**Kent**  
CORPORATION

800.800.Kent (5368) | [kenttesgo.com](http://kenttesgo.com)

# LCP ANTIRUST System

Reduce consumption and increase protection for your tube.  
Typical installs have seen a 60% reduction of oil consumption!

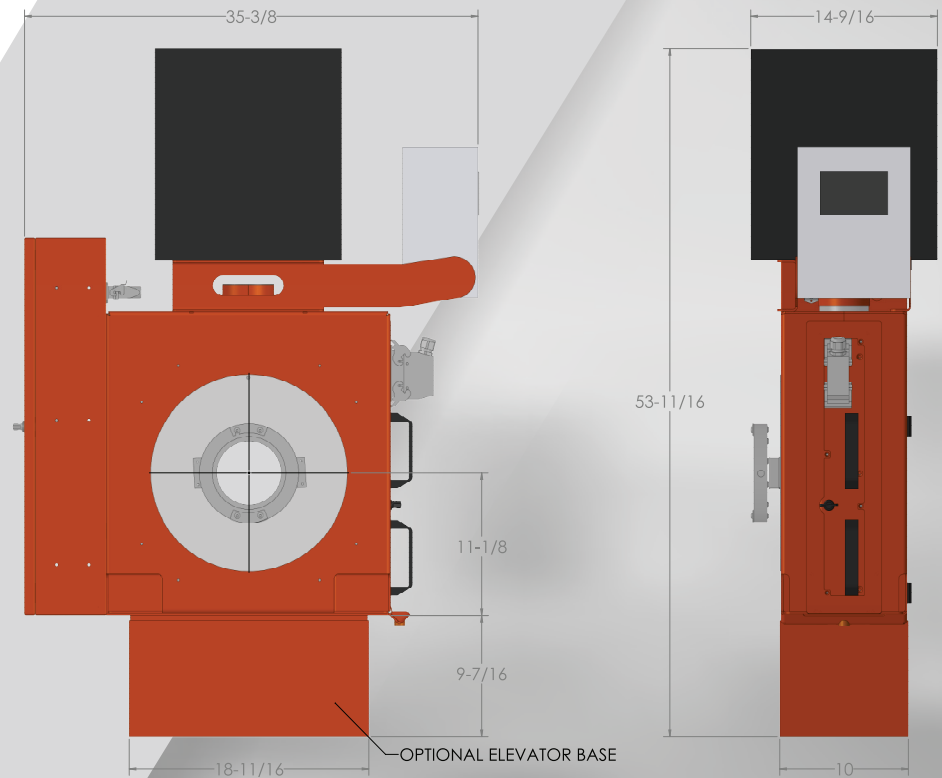

**\*DIMENSIONS SHOWN IN INCHES FOR ANTIRUST 04 AND 08**

LCP ANTIRUST systems are available from 0.080" to 16" diameter tubing.  
Contact a Kent specialist for recommendations on the best machine for your application.

	ANTIRUST MINI	ANTIRUST 04-S	ANTIRUST 04	ANTIRUST 08	ANTIRUST 12	ANTIRUST 1000
<b>ROUND</b>	MIN 0.08" MAX 0.40"	MIN 0.31" MAX 1.50"	MIN 0.31" MAX 3.00"	MIN 0.83" MAX 5.00"	MIN 2.00" MAX 8.62"	MIN 4.00" MAX 16.00"
<b>SQUARE</b>	N/A	MIN 0.31" MAX 1.50"	MIN 0.31" MAX 2.12"	MIN 0.58" MAX 3.54"	MIN 1.41" MAX 6.10"	MIN 2.83" MAX 11.30"
<b>RECTANGLE</b>	N/A	MIN 0.31" MAX 1.50"	MIN 0.31" MAX 2.12"	MIN 0.58" MAX 3.54"	MIN 1.41" MAX 6.10"	MIN 2.83" MAX 11.30"

- ▶ 12-month warranty
- ▶ Fully serviced and supported in the USA

#### AVAILABLE OPTIONS

- ▶ Flow control sensors to detect any nozzle clogs
- ▶ Oil/Mist Extraction System acts as a vacuum to collect over spray
- ▶ Oil Recovery System collects and filters RP and pumps it back to the main tank
- ▶ Height Adjustment to make sure the machine is always centered in-line
- ▶ Air knife to blow the tube completely dry of coolant and debris
- ▶ PMP (Preventative Maintenance Plans)

\*Above sizes are general recommendations, please contact us to discuss your specific application.